

# Standard Knapp Standard Knapp

an EMPLOYEE owned company

## ADJUSTABLE COMPRESSION SECTION

**UPGRADE FOR:**  
**Model 202/263**  
**Traymore**

### Benefits

- Quick Changeover.
- Square trays due to position of lugs at outermost corners during compression.
- Higher Reliability with Independent Clutch Protection and Reset.
- Ability to Handle a Wider Variety of Corrugate.



Figure 1.1 - Adjustable Compression Section

Adjustable Plastic Lugs for Quick Product Changeover.

Plastic Lugs positioned at the tray corners for enhanced control and product squaring.

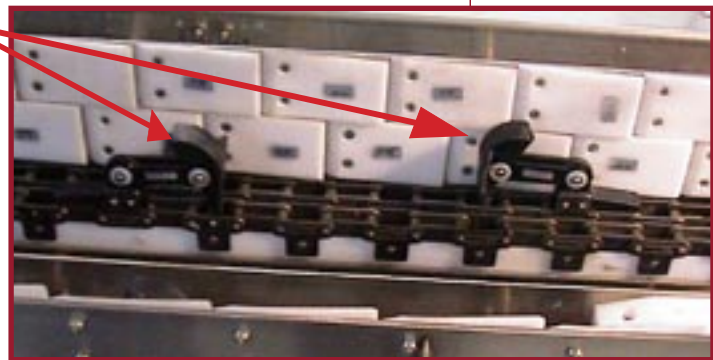

Figure 1.2 - Quick Adjusting Plastic Lugs

Call the Standard-Knapp Sales Department  
at 1-800-628-9565 for ordering information.

Standard-Knapp, Inc.  
127 Main Street  
Portland, CT 06480  
1-800-628-9565  
(fax) 860-342-0783  
[www.standard-knapp.com](http://www.standard-knapp.com)  
[info@standard-knapp.com](mailto:info@standard-knapp.com)

*Above photos were taken of a 296 Continuum Compression Section. Actual kit may differ.*

# Standard Knapp Standard Knapp

an EMPLOYEE owned company

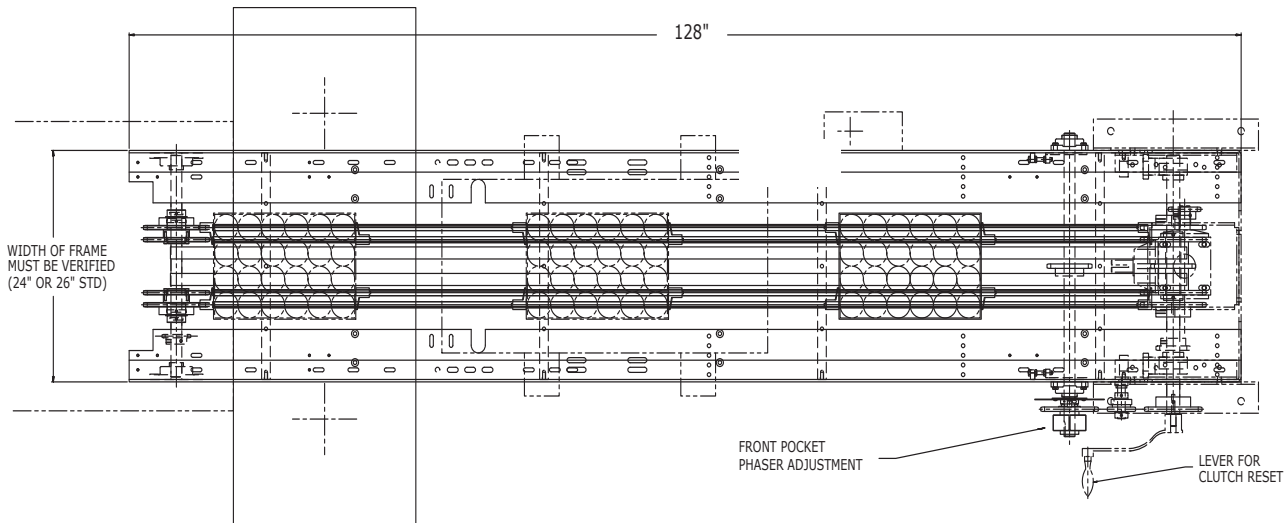

Figure 1.3 - Overhead View of New Compression Section

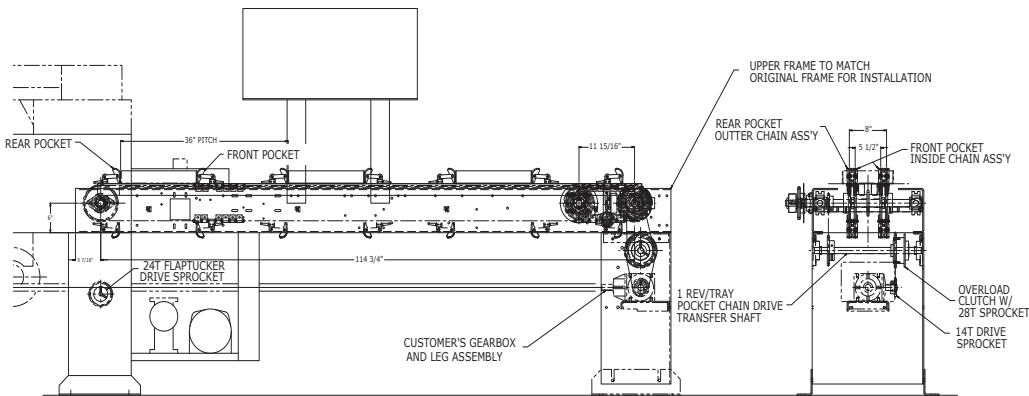

Figure 1.4 - Side View of New Compression Section

## SPECIFICATIONS

SPEED: No Limits

PRODUCT RANGE: Unchanged

AIR: None required

CONTROLS: None required

POWER: None required

CONSTRUCTION:

ESTIMATED WEIGHT:

INSTALLATION: Standard-Knapp service recommended

TIME TO INSTALL:

Call the Standard-Knapp Sales Department  
at 1-800-628-9565 for ordering information.