

Standard Knapp Standard Knapp

an EMPLOYEE owned company

TRAY TRANSPORT DEBRIS BRUSH

**UPGRADE FOR:
Model 296 Continuum
Traypacker**



Figure 1.1 - 'V'-Shaped Debris Brush

Stationary Brush sweeps
Debris off the Tray Transport

Pieces of Cardboard/Debris



Figure 1.2 - Tray with Debris
moving towards Brush

Benefits

- Effectively sweeps tray blank of debris and cardboard cut-outs.
- Increase accuracy of double tray detector. (If equipped)
- Prevents nuisance faults in tray transport area.
- Reduces jams at the product/tray merge.
- Prevents pieces of cardboard from lodging in tray guides.

Call the Standard-Knapp Sales Department at
1-800-628-9565 ext. 239 for ordering information.

Standard-Knapp, Inc.
127 Main Street
Portland, CT 06480
1-800-628-9565
(fax) 860-342-0783
www.standard-knapp.com
info@standard-knapp.com

Standard Knapp Standard Knapp

an EMPLOYEE owned company

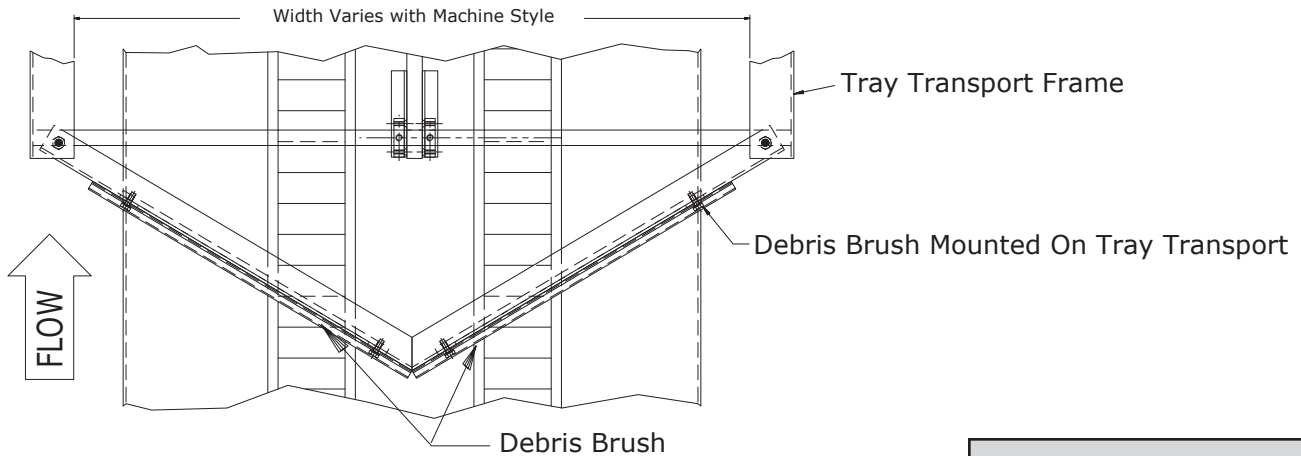

Figure 1.3 - Overhead View of Tray Transport Debris Brush

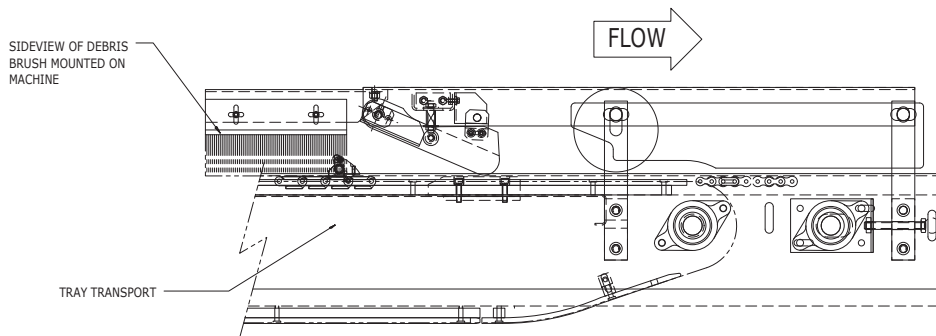

Figure 1.4 - Overhead View of Tray Transport Debris Brush

SPECIFICATIONS

SPEED: No Limits

PRODUCT RANGE: Unchanged

AIR: None required

CONTROLS: None required

POWER: None

CONSTRUCTION: Stainless Steel and Aluminum

ESTIMATED WEIGHT: 20 lbs.

INSTALLATION: Standard-Knapp service or plant maintenance.

TIME TO INSTALL: 1-2 hours

ADDITIONAL UPGRADE KITS AVAILABLE FOR YOUR 296 CONTINUUM

- TRAY BLANK INDEXER
- DOUBLE BLANK DETECTOR
- FILM SPINDLE SUPPORTS
- TRAY MAGAZINE BLANK RETAINER

Note: The Debris Brush Upgrade works well with the Double Blank Detection System.