

**Upgrade Name: Film Feed Hold-Down Kit**

**Machine Model(s): 296I, 296P**  
**Release Date: August 2002**  
**Approval: Jim Stanger**

**ENHANCEMENT  
BULLETIN**

**SK296IP080102**

**General Description:**

The 296 Film Feed Hold-down Kit improves the operation of the Continuum by preventing the film from wrapping itself around the roller while improving the ease of threading the film into the machine.

**Benefits:**

- Prevent the film from wrapping around the roller
- Improve the ease of threading the film into the machine
- Shorten Downtime
- Increase Machine Efficiency

**Parts List/Drawings:**

**DESIGN/SERVICE BRIEFS**

**Film Feed Hold-down Kit**

Standard-Knapp is pleased to offer a new 296 Upgrade Kit to improve the operation of your machine. Our primary objective in providing this kit is to:

- Prevent the film from wrapping around the roller
- Improve the ease of threading the film into the machine
- Shorten Downtime
- Increase Machine Efficiency

Part Number	Description	Quantity
596E2077-7	Finger Assembly	1
596E3131	Finger Support Plate	1
596A3130	Finger Support Block	2
596C3065-2	Installation Drawing	1
596C3011	Installation Drawing	1
	1/4-20 SOC HD SCR 3/4" LG	4
	1/4 Lock Washer	4
	5/16-18 Hex HD SCR 1" LG	2
	5/16-18 Hex HD SCR 1/2" LG	2
	5/16 Lock Washer	4

Standard-Knapp, Inc.  
 127 Main Street  
 Portland, Connecticut 06480  
 800-628-9565  
[www.standard-knapp.com](http://www.standard-knapp.com)  
 fax:860-342-0782  
[chassell@standard-knapp.com](mailto:chassell@standard-knapp.com)

Call the Standard-Knapp Sales Department at 1-860-342-1100 Ext. 208 or 352 for ordering information.

## Installation Instructions:



### **! WARNING !**

Before attempting to install the Film Feed Kit, all power and air must be removed from the machine by pressing an E-Stop and or following the **OSHA Lock-out/Tag-out Procedure (1910.147)**.

The new 296 Film Feed Guide Kit was designed to replace the existing guide and to be installed in a new location on the film feed bed. The location of the new guide places the "guide fingers" pointing upstream and in the direction of the film travel.

Once properly installed, the guide will:

- Prevent the film from wrapping around the roller.
- Improve the ease of threading the film into the machine and eliminate film "snags".
- Shorten downtime
- Increase machine efficiency

To properly install this new guide, first remove all parts from carton and familiarize yourself with each part. There should be a total of four(4) parts, hardware to mount the assembly and full size assembly drawings to aid in the installation. If any parts are missing or damaged, please call Standard-Knapp at 860-342-1100 as soon as possible for immediate replacement.

### **Carton Contents:**



#### • Parts

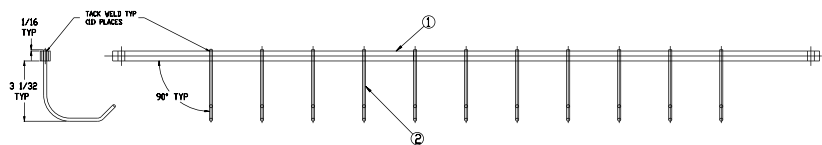

Finger Rod Assembly (1)

#### • Hardware

- (4) - 1/4-20 x 3/4" HD SCR
- (4) - 1/4 Lock Washers
- (2) - 5/16-18 x 1" Hex Bolt
- (2) - 5/16-18 x 1/2" Hex Bolt
- (4) - 5/16 Lock Washer

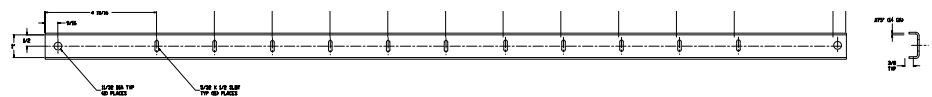

Finger Support Plate (1)

#### • Assembly Drawings

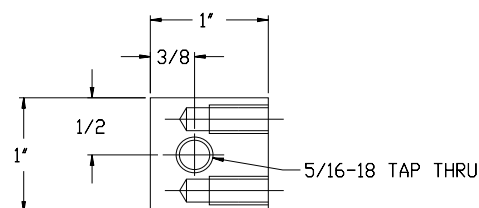

Finger Support Block (2)

**Figure 1-2.** Description of Parts

The existing Film Feed Finger Guide must first be removed and discarded.

The remaining steps will guide you through the entire installation:

1. Remove the two(2) finger mount bars (3596C3065-2) from each side of the film bed.
2. Drill one(1) 5/16"-18 Tap hole 5/8" deep into each finger mount bar at the exact location illustrated on drawing #596C3065-2. (See Page 5). A total of two(2) holes should be drilled and tapped.
3. With the film bed still mounted on machine, drill two(2) 9/32" holes into each sideplate. A total of four(4) holes should be drilled. (See page 6 drawing #596C3011 for exact hole locations.)



**NOTE:** When drilling these holes, be sure to protect all shafts and bearings from metal chips.

4. Mount the two(2) Finger Support Blocks (#596A3130) onto the sideplate through the two newly drilled holes using four (4) 1/4"-20 x 3/4" bolts and lock washers. Tighten firmly.
5. Re-mount the two finger mount bars which were removed earlier and drilled with new mounting holes.
6. Carefully guide the Finger Rod Assembly under the black rubber roller and secure to finger mount bar using two(2) 5/16"-18 x 1" and lock washers.
7. Position Finger Support Plate over Finger Rod Assembly making sure that each finger goes into a slotted hole. Secure with two(2) 5/16"-18 x 1/2" and lock washers.

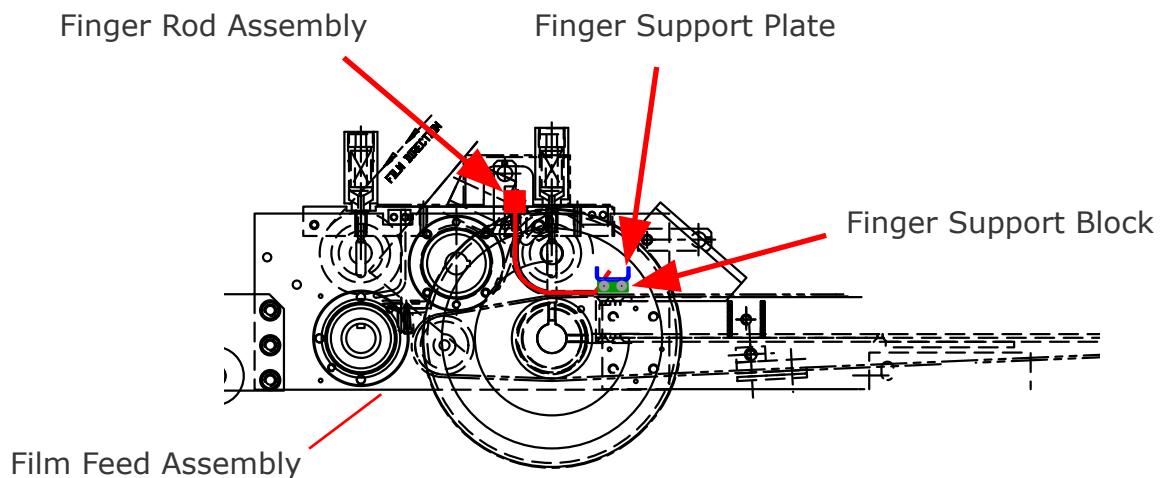

**Figure 1-2.** Location of new Film Feed Finger Guide

Before threading film into the machine, ensure that all fasteners are firmly tightened and that there is proper clearance for machine operation.

The installation of the new Film Feed Finger Guide is now complete and power can be restored to the machine.

If you experience any difficulties in this installation contact Standard-Knapp's service department at 860-342-1100.

## **How to Order:**

The 296 Film Feed Finger Guide Kit is now available for immediate delivery. The cost for this kit is \$XXX.XX plus shipping & handling.

To order this kit call or contact:

Standard-Knapp, Inc.  
127 Main Street  
Portland, CT 06480

Parts Department: 1-800-628-9565

Email us at: [parts@standard-knapp.com](mailto:parts@standard-knapp.com)



# Drawing #596C3065-2 Finger Mount

Exact location of hole to be drilled on top of each Finger Mount Bar.

