

Standard Knapp Standard Knapp

an EMPLOYEE owned company

TABLE LOCKOUT KIT

UPGRADE FOR:
Model 930
Case Packer



Figure 1.1 - Case Packer Lift Table (Shown in the up and locked position)

Benefits

- Provides a higher degree of safety for your operators.
- Prevents the table dropping to the home position when an emergency stop is pressed.
- Spring loaded pin automatically engages into a slotted plate preventing the table from suddenly dropping.



Figure 1.2 - Safety Solenoid and Slotted Plate



Figure 1.3 - Safety Solenoid engaged into Slot

Call the Standard-Knapp Sales Department at
1-800-628-9565 for ordering information.

Standard-Knapp, Inc.
127 Main Street
Portland, CT 06480
1-800-628-9565
(fax) 860-342-0783
www.standard-knapp.com
info@standard-knapp.com

Standard Knapp Standard Knapp

an EMPLOYEE owned company

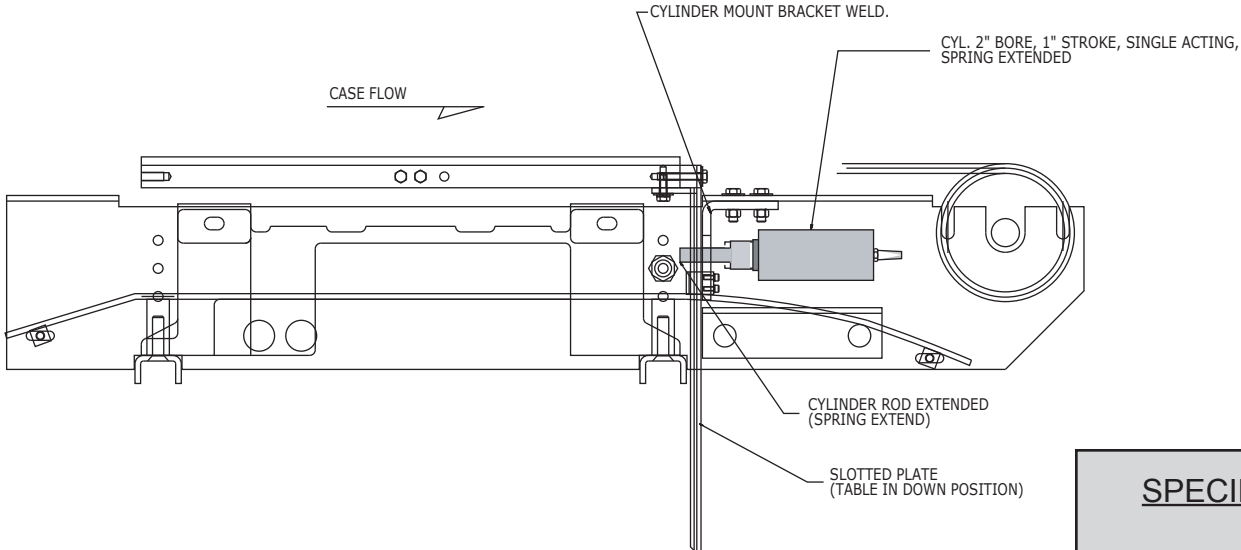

Figure 1.4 - Table Lock Safety Cylinder (Shown in engaged position)

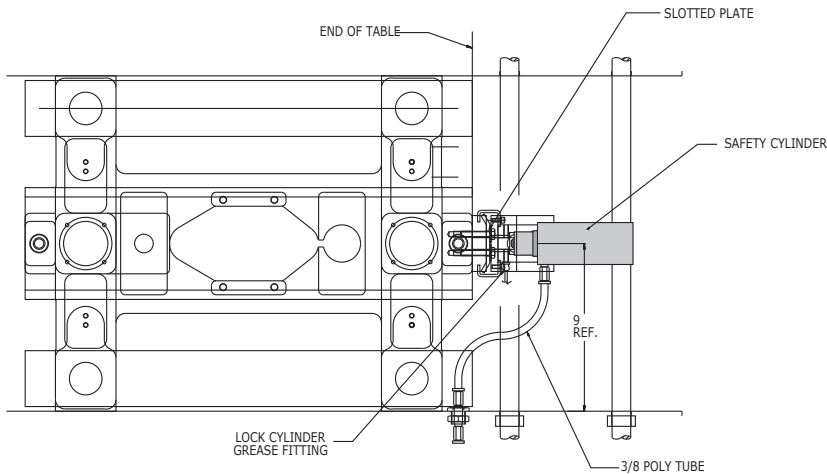

Figure 1.5 - Top view of mounted Safety Cylinder

SPECIFICATIONS

SPEED: No Limits

PRODUCT RANGE: Unchanged

AIR:

CONTROLS:

POWER:

CONSTRUCTION:

ESTIMATED WEIGHT: 15 lbs.

INSTALLATION: Standard-Knapp service recommended

TIME TO INSTALL: 6-8 hours

ADDITIONAL UPGRADE KITS AVAILABLE FOR YOUR 930 CASE PACKER

- Servo Driven Case Feed
- Pneumatic Flap Opener