

Standard Knapp Standard Knapp

an EMPLOYEE owned company

DISCHARGE ROLLER ASSEMBLY

**UPGRADE FOR:
949 Case Packer**

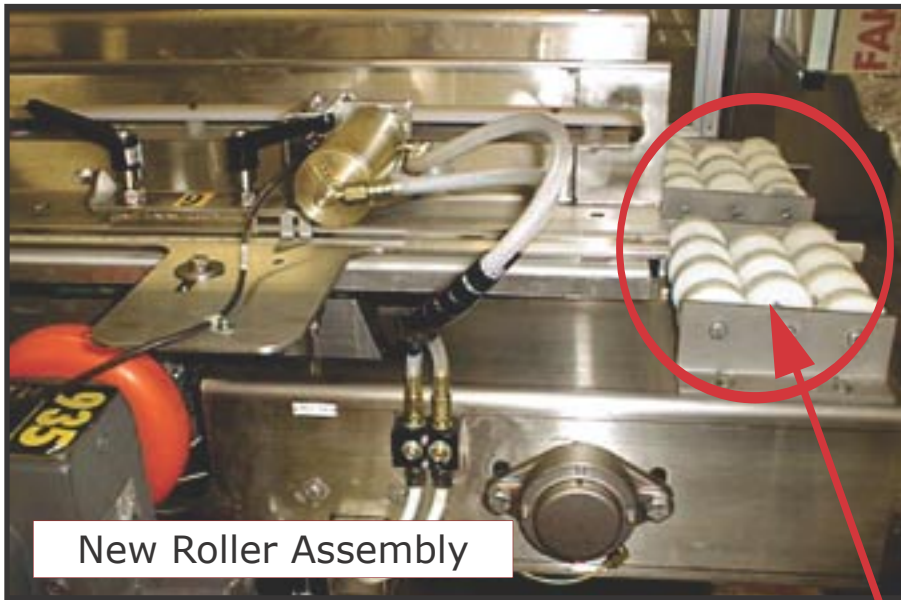

Figure 1.1 - New Multi-Roller Assembly Installed on Machine

Benefits

- Long-lasting, consistent operation.
- Easy to install.
- Reduces machine downtime.
- Virtually eliminates roller failure.
- Increases machine efficiency.



Figure 1.2 - Close-up of Old Style Single Roller Assembly

Call Standard-Knapp at 1-800-628-9565 more information.

Standard-Knapp, Inc.
127 Main Street
Portland, CT 06480
1-800-628-9565
(fax) 860-342-0783
www.standard-knapp.com
info@standard-knapp.com

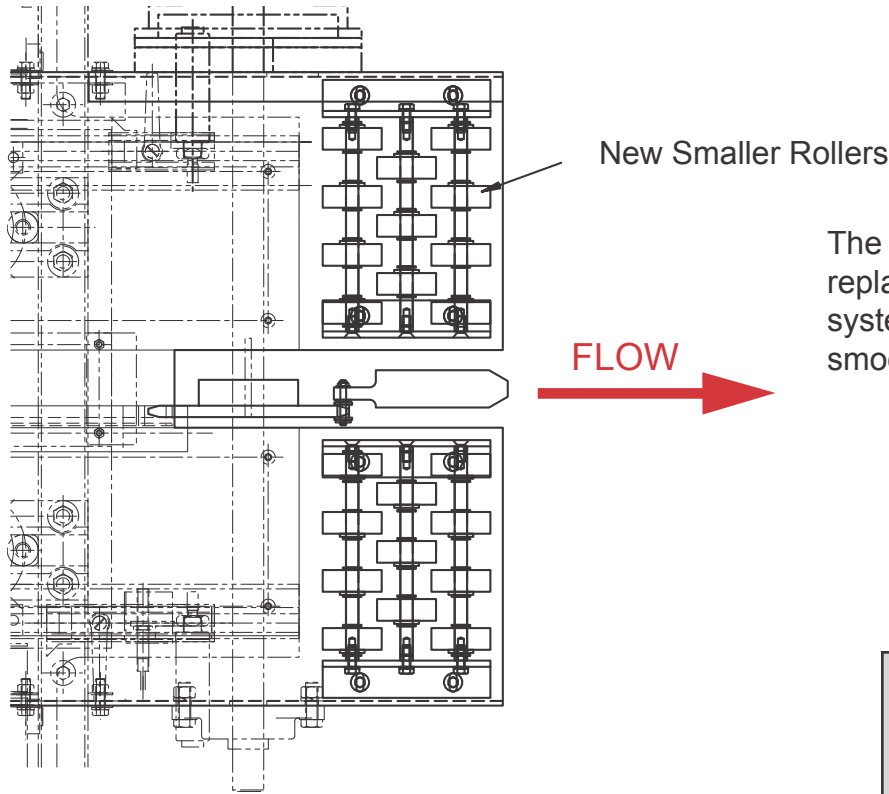

Figure 1.3 - Top View of the new Multi-Roller Assembly

The new multi-roller assembly replaces the original large roller system and allows for long-lasting smooth operation.

SPECIFICATIONS

SPEED: No Limits

PRODUCT RANGE: Unchanged

AIR: None required

CONTROLS: None required

POWER: None required

CONSTRUCTION: Nylon Wheels, Stainless Steel Shafts

ESTIMATED WEIGHT: 10 lbs.

INSTALLATION: Standard-Knapp Installation recommended

TIME TO INSTALL: 1 Hour

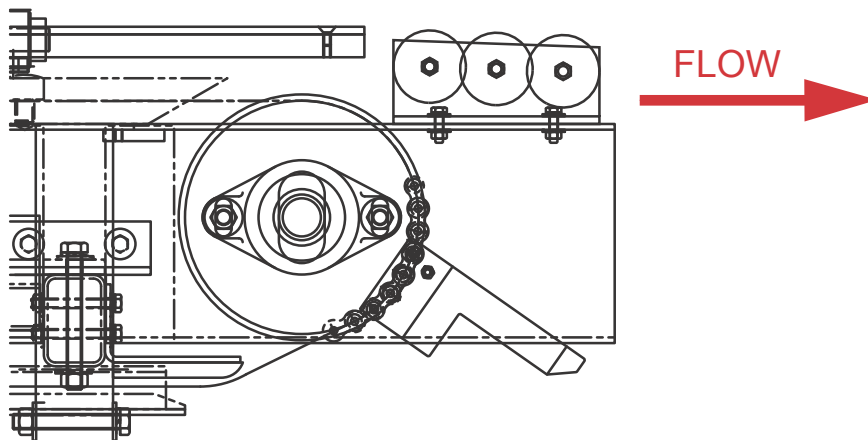

Figure 1.4 - Side View of the new Multi-Roller Assembly

ADDITIONAL UPGRADE KITS AVAILABLE FOR YOUR 949 CASE PACKER

- SPRING LOADED LIFT TABLE GEARS
- AIR HOSE MANIFOLD
- HEAVY DUTY LIFT TABLE
- QUICK CHANGE PRODUCT STOPS
- REAR CASE CLAMP
- MINOR FLAP GUIDES