

# *Continuum*<sup>TM</sup>

High Speed Tray Packer & Shrink Wrapper

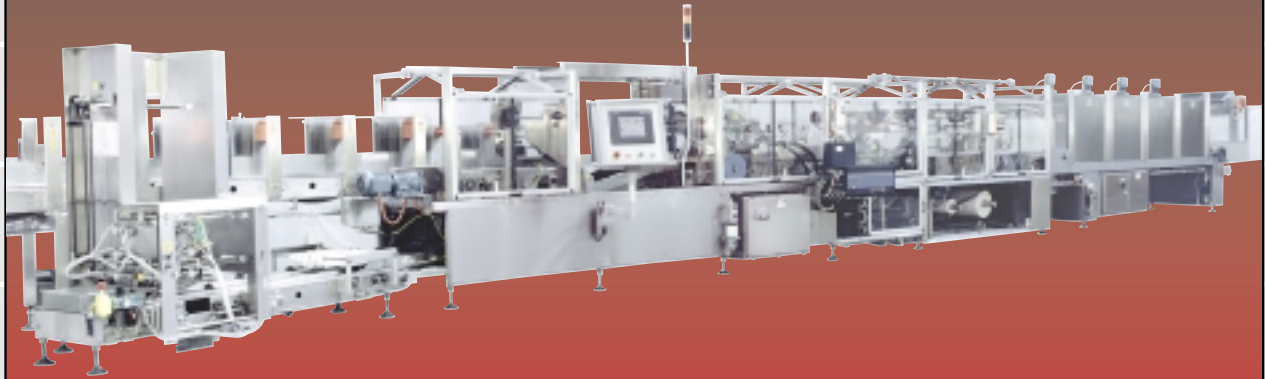

**Standard Knapp**  
**Standard Knapp**

an EMPLOYEE owned company

# ***Continuum***<sup>TM</sup> **High Speed Tray Packer & Shrink Wrapper**

Already proven at dozens of installations in the food and beverage industry, the Continuum Tray Packer is the best machine for achieving efficient operations. Including the optional integrated Shrink Wrapper and Tray Stacker, it has inherent product flexibility and changeover features that are unparalleled in the industry. Whether you are running glass, PET, metal or fiber cans into chipboard or corrugated trays, the Continuum is the right choice.

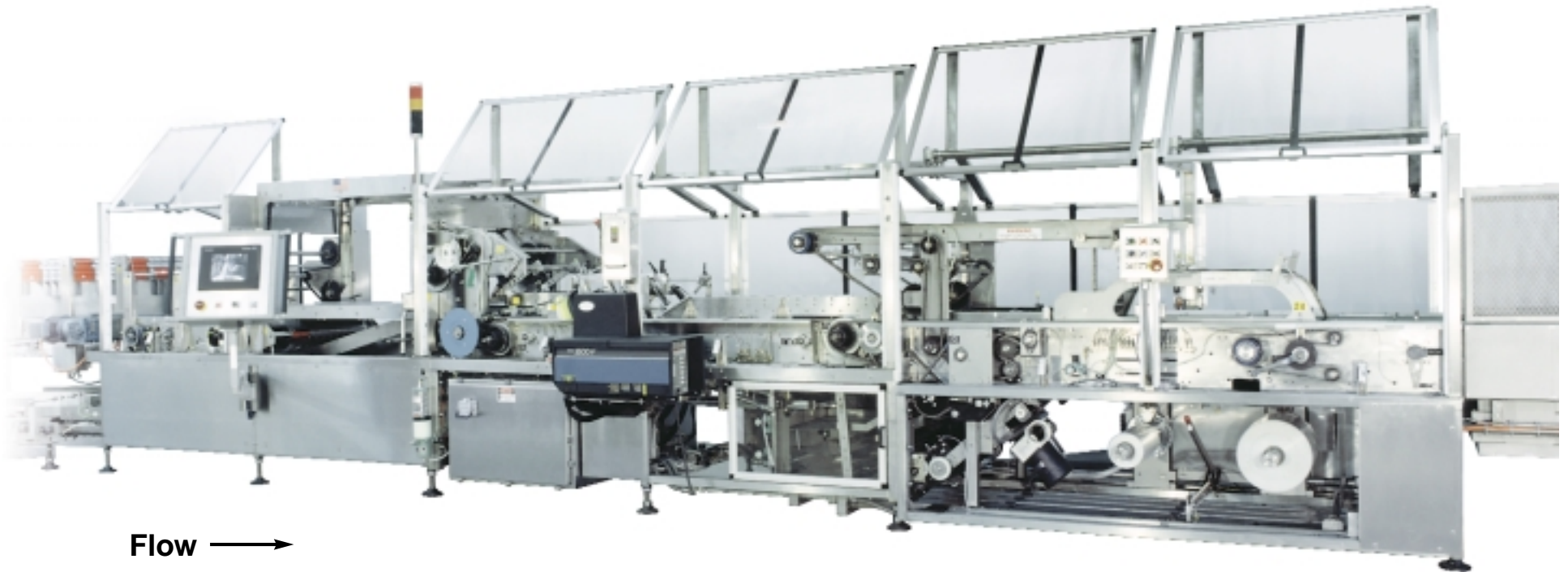

# Machine Benefits

## Reliable design provides high line efficiency

- Zero-gap infeed eliminates jams
- Positive tray magazine
- Precise servo grouper
- Four-gun glue system



296-I CHANGEOVER SETTING CHART



STEP	DESCRIPTION	FACTORY SETTING		FIELD SETTINGS
1	Zero-Gap Spacers (3)			
2	Infeed Spacers (5)			
3	Grouper Spacers (3)			
4	Pattern-Forming Guides			
5	Gap Plate	L	R	
6	Relief Gate Stop	L	R	
7	Stepped Fill-in Guide			
8	Down Product Detector			
9	Flight Bar Width	L	R	
10	Tray Flap Phaser			
11	Flap Tucker Width	L	R	
12	Flap Catcher Plates	L	R	
13	Tray Filler Plates	L	R	
14	Glue Gun Width	L	R	
15	Glue Gun Angle	L		
16	Tray Pocket Phaser			
17	Compression Width			
18	Magazine Width			
19	Magazine Length			
20	Tray Delivery Width			
21	Film Width			

## Quick changeover with no tweaking

- Simple, by-the-numbers system
- No additional tools necessary
- Color-coded lane spacers

## Flexibility

- Handles largest diameter range in the industry, with minimal change parts
- Loose containers and multipacks
- PET, metal, glass, HDPE, fiber cans
- Corrugated or chipboard trays
- Free-standing or integrated shrink wrapper
- Integrated tray stacker option



Machine Drive

## Low-maintenance design

- Machine drive has independent clutch protection
- Stainless Steel construction
- Gull Wing Guards allow complete access to all points
- Cluster lubrication with optional automatic pump

# Continuum™

## Description of Operation

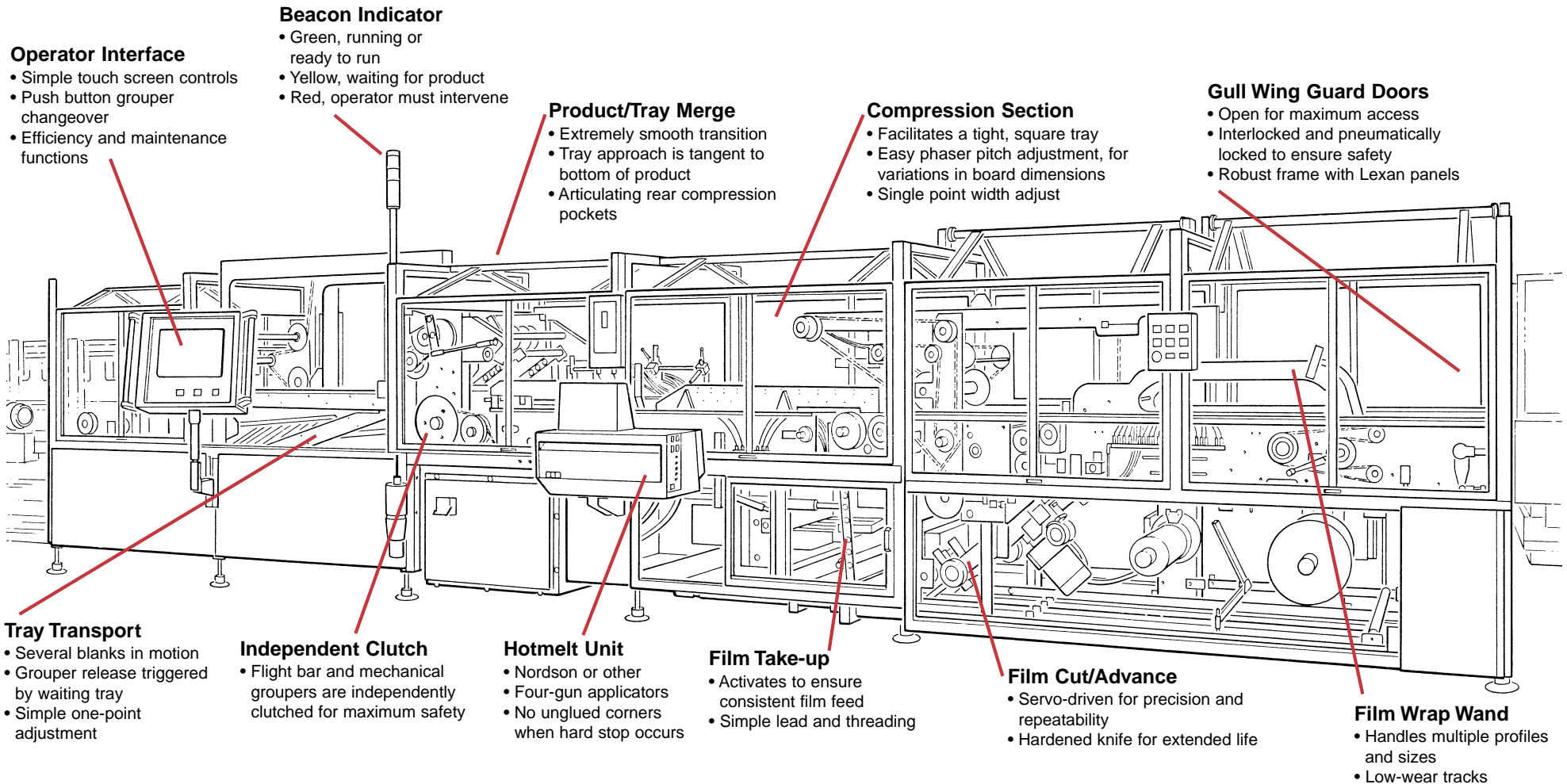

# Continuum Grouper Module

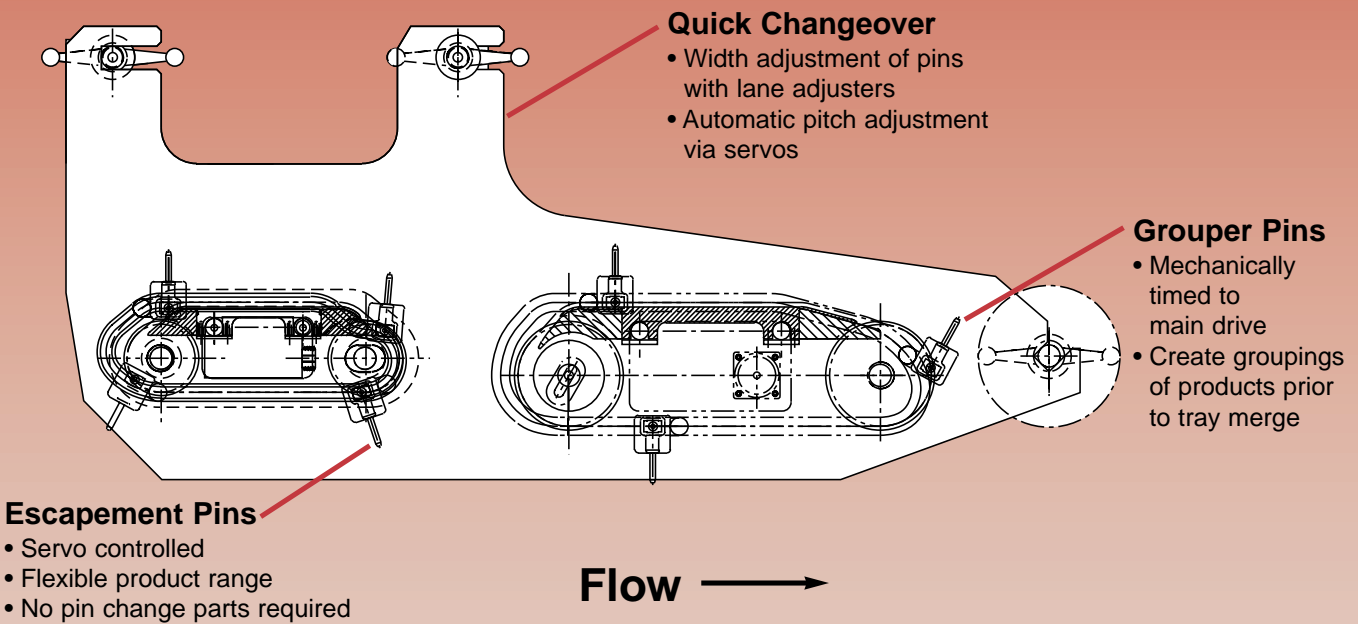

# Continuum Tray Magazine

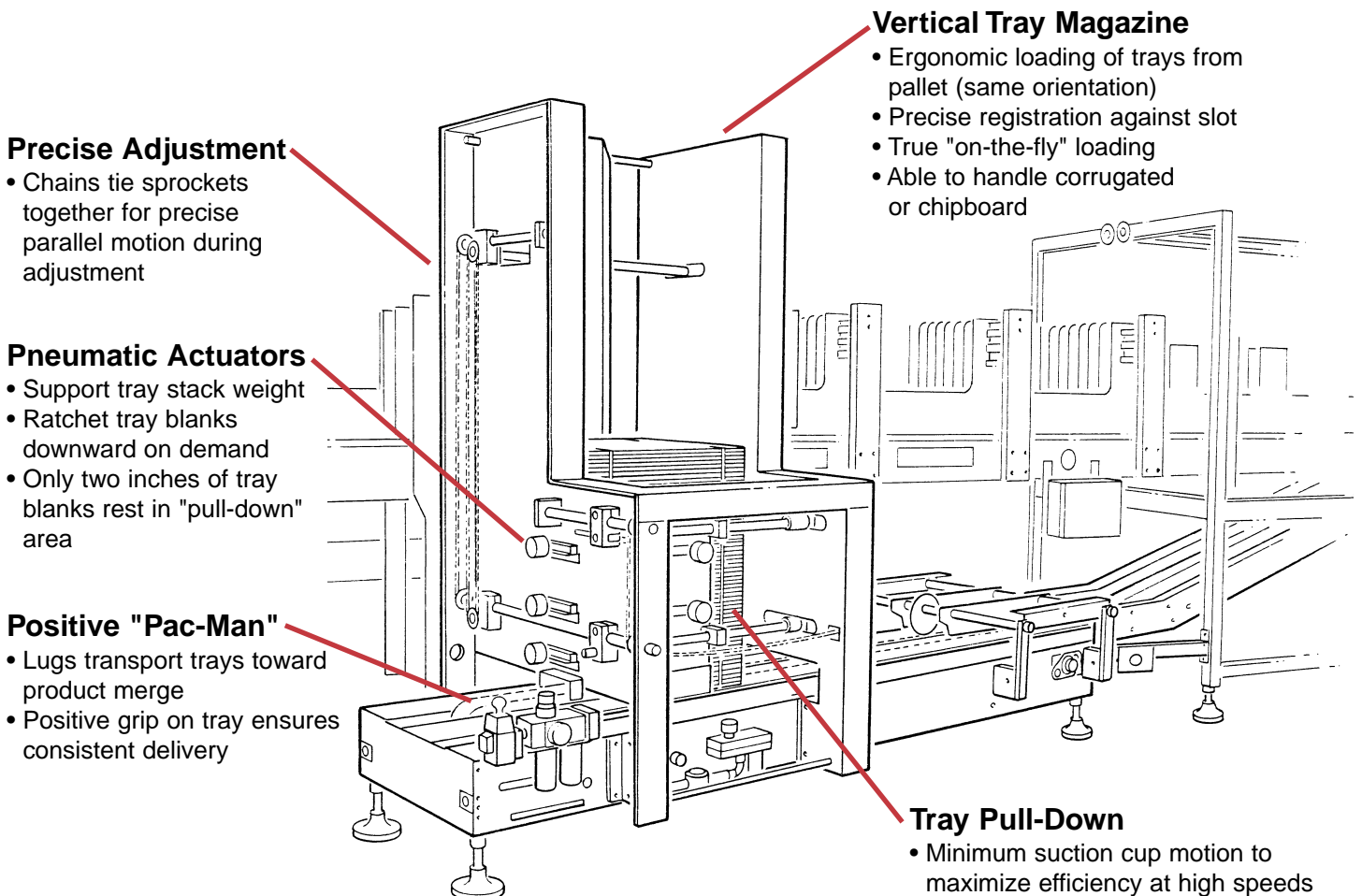

# Continuum™ Floor Plan

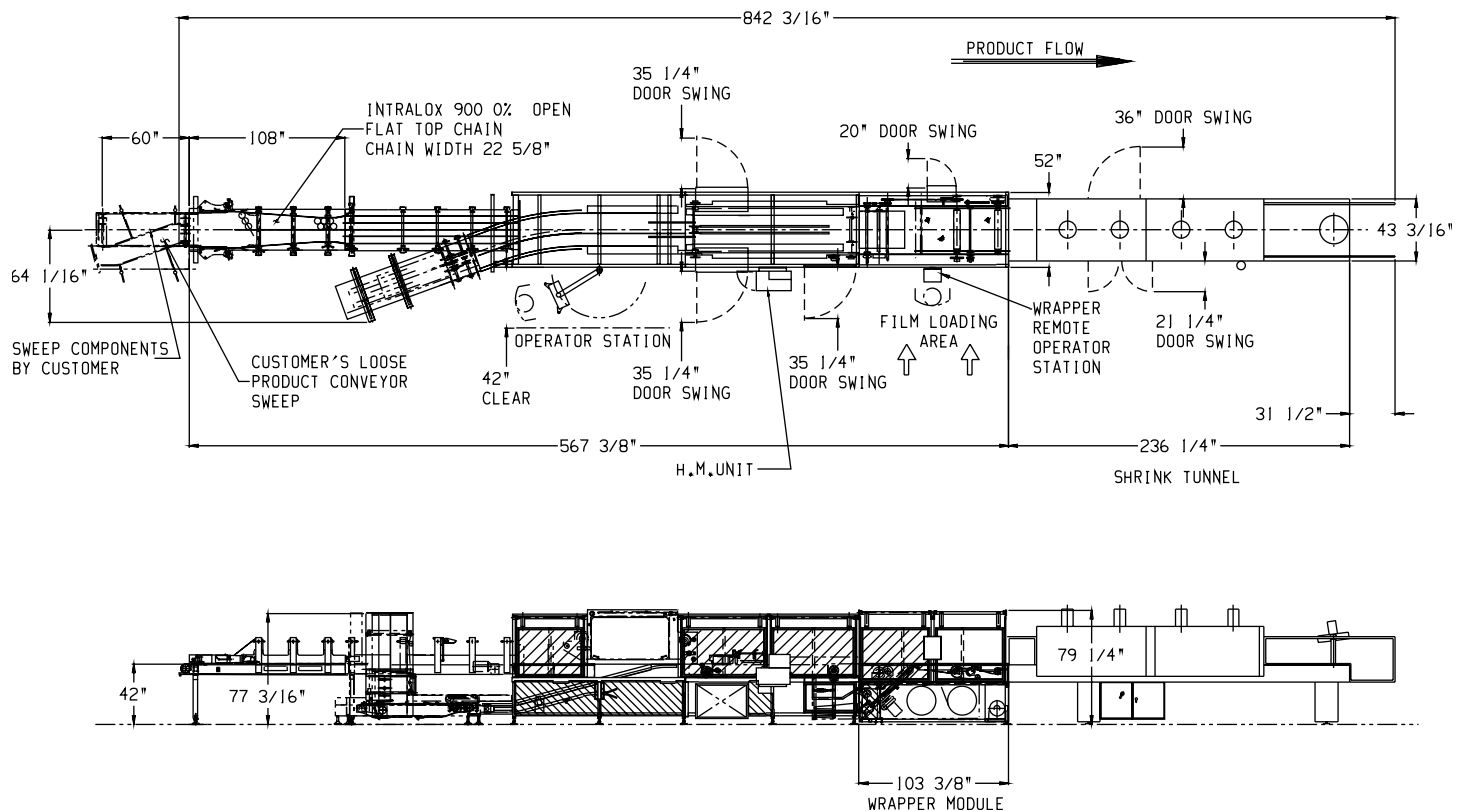

## Specifications\*

### Speed:

50, 70, 100 TPM

### Product Sizes:

1<sup>3</sup>/<sub>4</sub>" to 6<sup>1</sup>/<sub>4</sub>" dia.

### Products:

Glass jars, PET, HDPE, metal and fiber cans, HiCone, shrink bundles, paperboard overwrap, and others

### Tray Magazine:

Continuous loading vertical hopper, appr. 500 blank capacity

### Film Magazine:

21" diameter  
25" roll length

### Film Seal:

Overlap weld

### Air Requirements:

5 scfm @ 90 psi

### Power Requirements:

460v, 60 cycle, 3 phase, 200A

### Servo Motors:

A-B 1394 and A-B 1398  
motion controller

### Tunnel Heat:

72 kw

### Main Control Enclosure:

NEMA 4, painted Steel-it®

### Machine-Mounted Enclosures:

NEMA 4

### Controls:

24 vDC with A-B SLC 500,  
Modicon, or other

### Operator Interface:

PanelView 1000 or other

\* Standard-Knapp is committed to continuous product improvement. Specifications subject to change without notice.



an EMPLOYEE owned company

## STANDARD-KNAPP, INC.

127 Main Street, Portland, CT 06480 U.S.A.

**SALES PHONE:** (860) 342-1100, ext. 239

**SALES FAX:** (860) 342-0782

**EMAIL:** info@standard-knapp.com

**WEB SITE:** www.standard-knapp.com